

# IXCONNECT KEKU FASTENERS

- > For securing trims and cladding panels directly to walls with no wooden subframe
- > For construction of cavity-type doors to accommodate sound insulating material or cable ducting
- > For ceiling claddings as well as walls
- > All panels, once installed, can be easily removed at any time and with no special tools
- > Advantages
  - Easy pre-planning
  - Wide range of designs with different panel materials and other materials
  - Systematic design with prefabricated parts
  - Quick, easy dismantling at any time
  - Reusable, recyclable



-  > Supporting plastic fittings may not be treated with chemical solvents or aggressive greases
- > Makrolon has a temperature stability from -100°C to +135°C

## Panel component, with lip

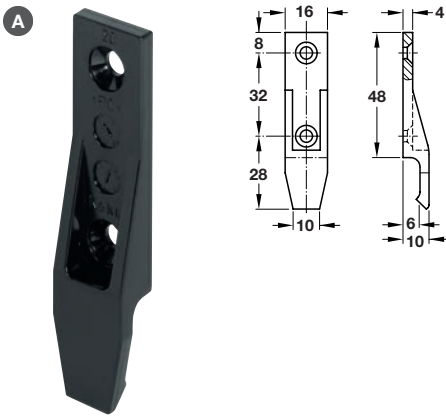

- > Screw fixing with Hospa or Varianta screws
- > Max load capacity of pair of fittings is 20 kg
- > Black Makrolon
- > Order qty: Multiples of 50 pcs



 Angled component C or D must be ordered separately, shown on page 99

Mounting with	With lip
Hospa screws	262.49.356
Varianta screws	262.49.357

## Spacer plate

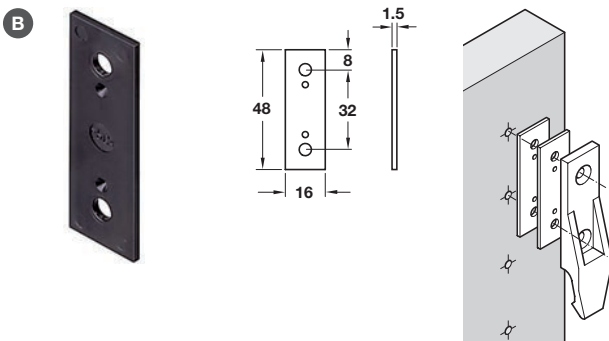

- > For panel component A
- > Black polycarbonate
- > Order qty: Multiples of 50 pcs



Mounting with	Cat. No.
Varianta screws	262.49.355

 > Hospa screws are shown in **Section 13** pages **8-16**  
 > Varianta screws are shown in **Section 13** pages **21-23**